

Product information presented here reflects conditions at time of publication. Consult factory regarding discrepancies or inconsistencies.



MAIL TO: P.O. BOX 16347 • Louisville, KY 40256-0347
SHIP TO: 3649 Cane Run Road • Louisville, KY 40211-1961
TEL: (502) 778-2731 • 1 (800) 928-PUMP • **FAX:** (502) 774-3624

Visit our web site:
zoellerpumps.com

REPLACEMENT PARTS LIST FOR MODELS:

M3161 AUTOMATIC 115V
N3161 NONAUTOMATIC 115V
D3161 AUTOMATIC 230V
E3161 NONAUTOMATIC 230V

Consult factory for all other models

TO ORDER REPLACEMENT PARTS:

PLEASE FURNISH THE FOLLOWING INFORMATION:

- Model Number.
- Part Number of Pump.
- Part Number and Description of part.

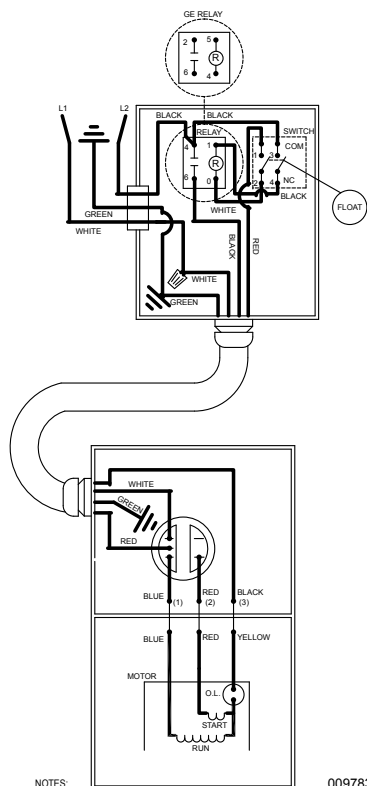

NOTES:
INSULATORS REQUIRED ON GE RELAY TERMINALS 2 & 5;
OMRON RELAY TERMINALS 1 & 4.

WIRING DIAGRAM FOR MODELS
"M3161" ALL REVISIONS AND
"D3161" ALL REVISIONS
2/95 thru Current

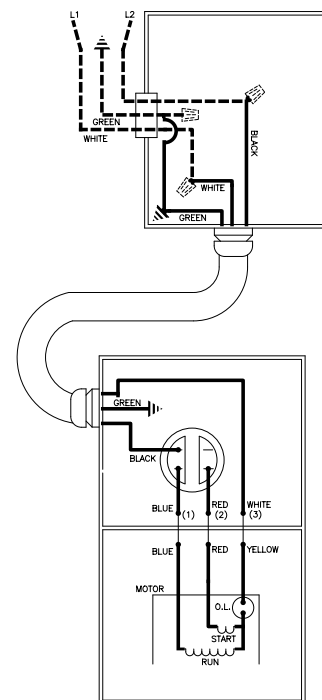

009784

WIRING DIAGRAM FOR MODELS
"N3161" ALL REVISIONS AND
"E3161" ALL REVISIONS
2/95 thru Current

REPLACEMENT PARTS LIST FOR MODELS "M3161" & "D3161".

See back page for illustration.

REF. NO.	DESCRIPTION	QTY	NOTES	MODELS:									
				M3161-A	M3161-B	M3161-C	M3161-D	M3161-E	D3161-A	D3161-B	D3161-C	D3161-D	
				3/95 thru 9/98	10/98 thru 9/01	10/01 thru 11/09	12/09 thru 1/16	2/16 thru Current	10/98 thru 9/01	10/01 thru 11/09	12/09 thru 1/16	2/16 thru Current	
1	• HANDLE	1		217069	217069	217069	217069	217069	217069	217069	217069	217069	
2	COVER & HANDLE	1		009662	009662	009662	009662	009662	009662	009662	009662	009662	
3	• GASKET,CASE OR COVER	1		012649	012649	012649	012649	012649	012649	012649	012649	012649	
4	• WIRE PKG.	1		004756	004756	004756	004756	004756	004756	004756	004756	004756	
5	CAPACITOR & CLAMP ASM	1		003575	003575	003575	003575	003575	003575	002381	002381	002381	
6	• SEAL - THRU WALL TERM.	3		003402	003402	003402	003402	003402	003402	003402	003402	003402	
7	MTR. HSG. BRG. STATOR & TERM.	1		009974	009974	009974	150604	150604	009975	009975	150605	150605	
8	BEARING, UPPER SLEEVE	1		001012	001012	001012	NA	NA	001012	001012	NA	NA	
	• BEARING, UPPER BALL			NA	NA	NA	006703	006703	NA	NA	006703	006703	
9	ROTOR (115V/230V)	1		002701	002701	002701	150574	150574	002701	002701	150575	150575	
10	BEARING, LOWER	1		001013	001013	001013	010069	010069	001013	001013	010069	010069	
11	• SEAL, MTR. HSG.	1		012648	012648	012648	012648	012648	012648	012648	012648	012648	
12	ADAPTER	1		001003	001003	001003	001003	001003	001003	001003	001003	001003	
13	• SEAL, SHAFT	1		019068	019068	019068	019068	019068	019068	019068	019068	019068	
14	IMPELLER "161"	1		004307	004307	004307	004307	004307	004307	004307	004307	004307	
15	HOUSING, PUMP-MACH 161/185/188	1		004188	004188	004188	004188	004188	004188	004188	004188	004188	
16	STRAINER PLATE	1		137008	137008	137008	137008	137008	137008	137008	137008	137008	
17	• PLUG BRASS	2		015203	015203	015203	015203	015203	015203	015203	015203	015203	
18	• OIL, DIELECTRIC	1		006065	006065	006065	011066	011066	006065	006065	011066	011066	
19	FLANGE PKG. 2"	1		10-1305	10-1305	10-1305	10-1305	10-1305	10-1305	10-1305	10-1305	10-1305	
	FLANGE PKG. 3"			10-1306	10-1306	10-1306	10-1306	10-1306	10-1306	10-1306	10-1306	10-1306	
20	CASE HANDLE & ASM.	1		007088	007088	007088	007088	007088	007088	007088	007088	007088	
21	GUARD	1		267008	267008	267008	267008	267008	267008	267008	267008	267008	
22	• ARM & SEAL ASM.	1		004741	004741	004741	004741	004741	004741	004741	004741	004741	
23	CASE & SWITCH	1		009977	009977	009977	009977	009977	009977	009977	009977	009977	
24	SWITCH ASM. "160/180/290"	1		004744	004744	004744	004744	004744	004744	004744	004744	004744	
25	• GASKET - CASE OR COVER	1		014555	014555	014555	014555	014555	014555	014555	014555	014555	
26	HOUSING, SWITCH	1		009454	009454	009454	009454	009454	009453	009453	009453	009453	
27	FLOAT	1		034019	034019	034019	034019	034019	034019	034019	034019	034019	
28	FLOAT ROD ASM.	1		005352	005352	005352	005352	005352	005352	005352	005352	005352	
29	FLOAT - MACH.	1		004912	004912	004912	004912	004912	004912	004912	004912	004912	
30	CORD TERM. & SEAL 115V	1		009976	009976	009976	009976	009976	009980	009980	009980	009980	
31	STRAIN RELIEF	2		001770	001770	001770	001770	N/A	001770	001770	001770	N/A	
32	SEAL, CORD - ASM. & STR. RLF.	1		015635	015635	015635	015635	015635	004721	004721	004721	004721	
33	• SEAL ASM. CONDUIT	2		009643	009643	009643	009643	009643	009643	009643	009643	009643	
34	CORDAGE, CONDUIT & SEALS	1		009978	009978	009978	009978	009978	009978	009978	009978	009978	
35	CONDUIT 3'	1		005167	005167	005167	005167	005167	005167	005167	005167	005167	
36	CORDAGE & TERMS.	1		009979	009979	009979	009979	009979	009979	009979	009979	009979	
37	CLAMP, #40 SS WORM	1	7	004304	004304	004304	004304	004304	004304	004304	004304	004304	
	CLAMP, #60 SS WORM	2	7	004913	004913	004913	004913	004913	004913	004913	004913	004913	
38	• WIRENUT CONNECTOR	1		001776	001776	001776	001776	001776	001776	001776	001776	001776	
39	RELAY 115V G1 (&G5)	1		217092	217092	217092	217092	153813	217093	217093	217093	153814	
40	• SCREW, .25-20 X .75" HHM-SS	8		001916	001916	001916	001916	001916	001916	001916	001916	001916	
41	• SCREW, #6-32 X .25" RHM SL STLGR	5		001877	001877	001877	001877	001877	001877	001877	001877	001877	
42	• SCREW, .313 - 18 X 1" HH CAP - SS	4		002608	002608	002608	002608	002608	002608	002608	002608	002608	
43	• SCREW, #10-24 X .375" RHM SL-SS	5		001883	001883	001883	001883	001883	001883	001883	001883	001883	
44	• SCREW, #6-32 X .438" RH PH TP STZI	2		004644	004644	004644	004644	004644	004644	004644	004644	004644	
45	• SCREW, .5 - 13 X 2" HH CAP-SS	2		001909	001909	001909	001909	001909	001909	001909	001909	001909	
46	• WASHER, SS - 1/2" DIA. STD. FLAT	2		002115	002115	002115	002115	002115	002115	002115	002115	002115	
47	• SCREW, .25 - 20 X 1" HHM-SS	4		007790	007790	007790	007790	007790	007790	007790	007790	007790	
48	• SEM, 10-24X.375 HH-SL TC .688 WASH.	2		002000	002000	002000	002000	002000	002000	002000	002000	002000	
49	INSULATION-INSULATOR FLAG TERMINAL	2		001797	001797	001797	001797	001797	001797	001797	001797	001797	
▣	REBUILD KIT	1		009987	009987	009987	150610	150610	009987	009987	150610	150610	

• Items included in Rebuild Kit.

▣ Not shown in illustration.

REPLACEMENT PARTS LIST FOR MODELS "N3161" & "E3161".

See back page for illustration.

MODELS:				N3161-A	N3161-B	N3161-C	N3161-D	E3161-A	E3161-B	E3161-C
REF. NO.	DESCRIPTION	QTY	NOTES	3/95 thru 9/98	10/98 thru 9/01	10/01 thru 11/09	12/09 thru Current	10/98 thru 9/01	10/01 thru 11/09	12/09 thru Current
1	• HANDLE	1		217069	217069	217069	217069	217069	217069	217069
2	COVER & HANDLE	1		009662	009662	009662	009662	009662	009662	009662
3	• GASKET,CASE OR COVER	1		012649	012649	012649	012649	012649	012649	012649
4	• WIRE PKG.	1		004756	004756	004756	004756	004756	004756	004756
5	CAPACITOR & CLAMP ASM	1		003575	003575	003575	003575	002381	002381	002381
6	• SEAL - THRU WALL TERM.	3		003402	003402	003402	003402	003402	003402	003402
7	MTR. HSG. BRG. STATOR & TERM.	1		009974	009974	009974	150604	009975	009975	150605
8	BEARING, UPPER SLEEVE	1		001012	001012	001012	NA	001012	001012	NA
	• BEARING, UPPER BALL			NA	NA	NA	006703	NA	NA	006703
9	ROTOR (115V/230V)	1		002701	002701	002701	150574	002701	002701	150575
10	BEARING, LOWER	1		001013	001013	001013	010069	001013	001013	010069
11	• SEAL, MTR. HSG.	1		012648	012648	012648	012648	012648	012648	012648
12	ADAPTER	1		001003	001003	001003	001003	001003	001003	001003
13	• SEAL, SHAFT	1		019068	019068	019068	019068	019068	019068	019068
14	IMPELLER "161"	1		004307	004307	004307	004307	004307	004307	004307
15	HOUSING, PUMP-MACH 161/185/188	1		004188	004188	004188	004188	004188	004188	004188
16	STRAINER PLATE	1		137008	137008	137008	137008	137008	137008	137008
17	• PLUG BRASS	2		015203	015203	015203	015203	015203	015203	015203
18	• OIL, DIELECTRIC	1		006065	006065	006065	011066	006065	006065	011066
19	FLANGE PKG. 2"	1		10-1305	10-1305	10-1305	10-1305	10-1305	10-1305	10-1305
	FLANGE PKG. 3"			10-1306	10-1306	10-1306	10-1306	10-1306	10-1306	10-1306
20	COVER, PLATE & GASKET	1		267051	267051	267051	267051	267051	267051	267051
21	• GASKET - CASE OR COVER	1		014555	014555	014555	014555	014555	014555	014555
22	HOUSING, SWITCH	1		009454	009454	009454	009454	009454	009454	009454
23	CLAMP, #60 SS WORM	2		004913	004913	004913	004913	004913	004913	004913
24	STRAIN RELIEF	2		001770	001770	001770	N/A	001770	001770	N/A
25	• SEAL ASM. CONDUIT	2		009643	009643	009643	009643	009643	009643	009643
26	CORDAGE, CONDUIT & SEALS	1		009656	009656	009656	009656	009656	009656	009656
27	CONDUIT 6"	1		005252	005252	005252	005252	005252	005252	005252
28	CORDAGE & TERMS.	1		005354	005354	005354	005354	005354	005354	005354
29	• SCREW, .25-20 X .75" HHM-SS	8		001916	001916	001916	001916	001916	001916	001916
30	• SCREW, #6-32 X .25" RHM SL STLGR	4		001877	001877	001877	001877	001877	001877	001877
31	• SCREW, .25 - 20 X 1" HHM-SS	4		007790	007790	007790	007790	007790	007790	007790
32	• SCREW, .313 - 18 X 1" HH CAP - SS	4		002608	002608	002608	002608	002608	002608	002608
33	• SCREW, #10-24 X .375" RHM SL-SS	3		001883	001883	001883	001883	001883	001883	001883
34	• SCREW, .5 - 13 X 2" HH CAP-SS	2		001909	001909	001909	001909	001909	001909	001909
35	• WASHER, SS - 1/2" DIA. STD. FLAT	2		002115	002115	002115	002115	002115	002115	002115
36	• SEM, 10-24X.375 HH-SL TC .688 WASH.	2		002000	002000	002000	002000	002000	002000	002000
37	HANDLE	1		267032	267032	267032	267032	267032	267032	267032
38	RETAINER, HANDLE	2		267053	267053	267053	267053	267053	267053	267053
▣	REBUILD KIT	1		009987	009987	009987	150610	009987	009987	150610

• Items included in Rebuild Kit.

▣ Not shown in illustration.

NOTES:

- 1) Strain Relief (Item 31) can be purchased separately, but is included with Cord, Terminal & Seal Assembly (Item 30) and with Seal, Cord Assembly (Item 32 and 33).
- 2) Mtr. Hsg., Brg., Stator & Term. (Item 7) are preassembled at the factory and must be replaced as a unit. Stator is permanently attached to the Motor Housing. Plug (Item 17); Seal, Thru Wall Term. (Item 6) and Bearing - Upper (Item 10) are replaceable.
- 3) When ordering Motor Housing, Bearing, Stator and Term. (Item 7) or Rotor (Item 9) specify either GE or Emerson motor. GE motor can be identified by (4) holes spaced at 90° around the outside diameter of the stator. Emerson motor can be identified by (4) flat edges spaced at 90° around the outside diameter of the stator.
- 4) See FM0160 Parts Price Sheet for listing of parts prices.
- 5) "NA" indicates, not applicable.
- 6) If an "X" follows Model No., or Date Mfg. on brass ID tag, consult factory for ordering any parts.
- 7) Discharge pipe size determines clamp size to order. When using 3" discharge pipe, do not order clamp 004304; instead order (3) 004913.

REPLACEMENT PARTS ILLUSTRATION FOR MODEL "M3161" and "D3161"

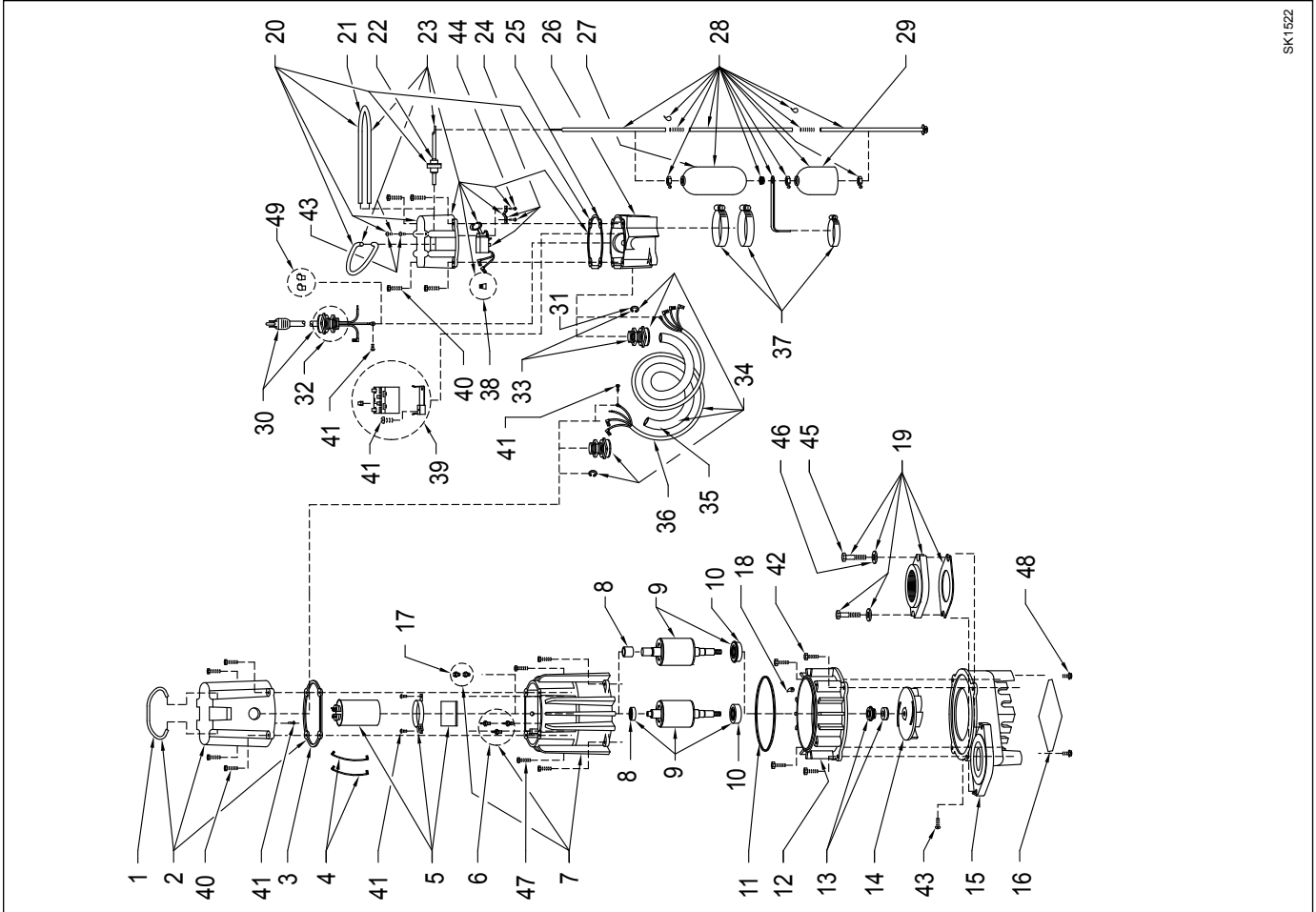

SK1522

REPLACEMENT PARTS ILLUSTRATION FOR MODEL "N3161" and "E3161"

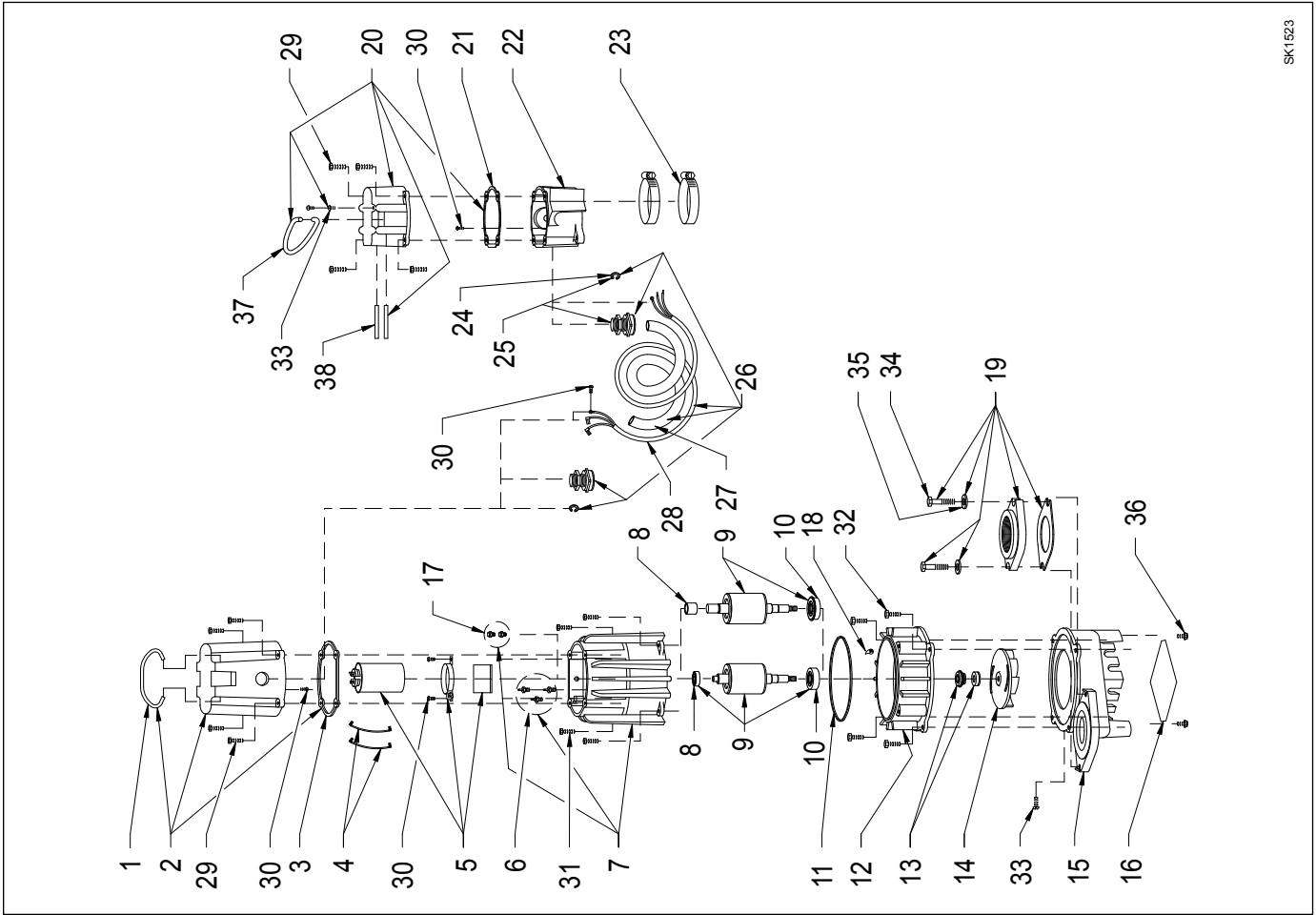

SK1523